

Scaled Digester Cross Section; Approximate size will be 17' tall by 10' wide, circular in 180 Degrees

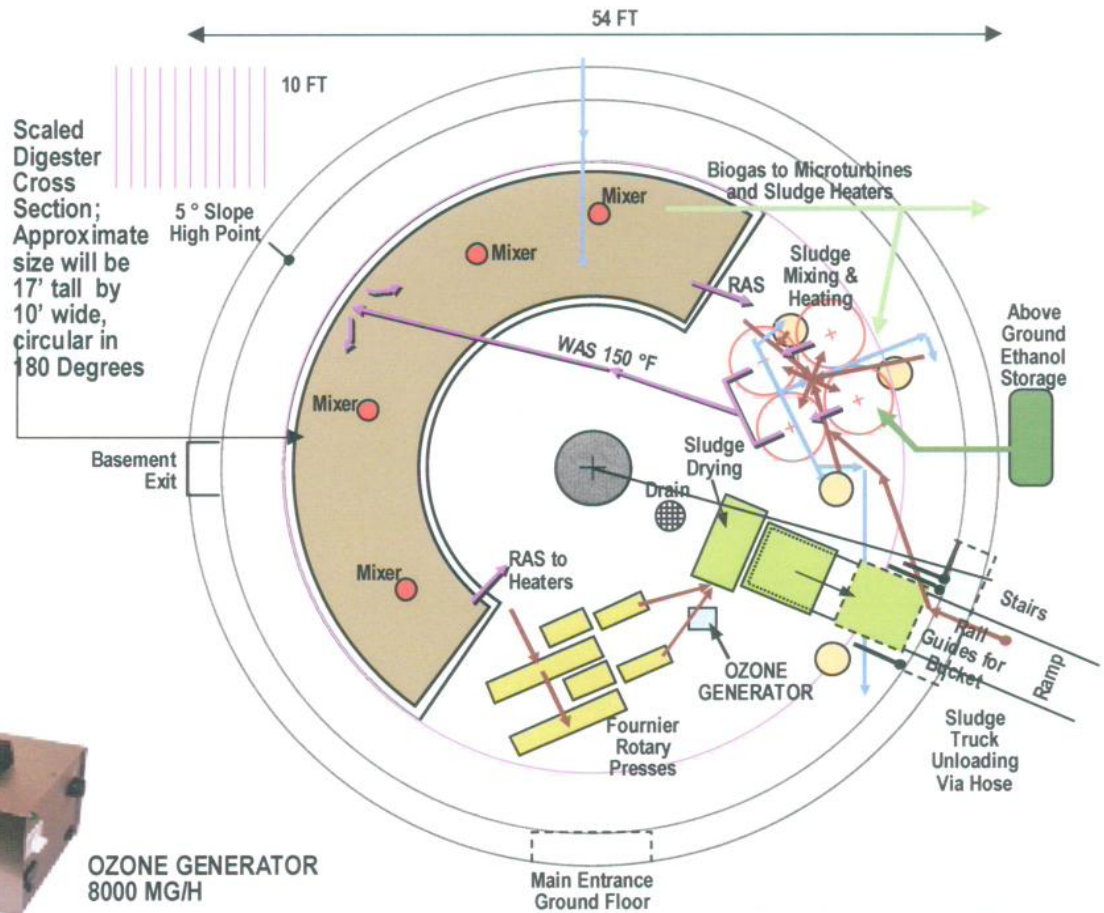

**FOURNIER ROTARY PRESS**

[http://www.rotary-press.com/dewatering-equipment/specifications\\_ang.cfm?cfgSection=specifications](http://www.rotary-press.com/dewatering-equipment/specifications_ang.cfm?cfgSection=specifications)

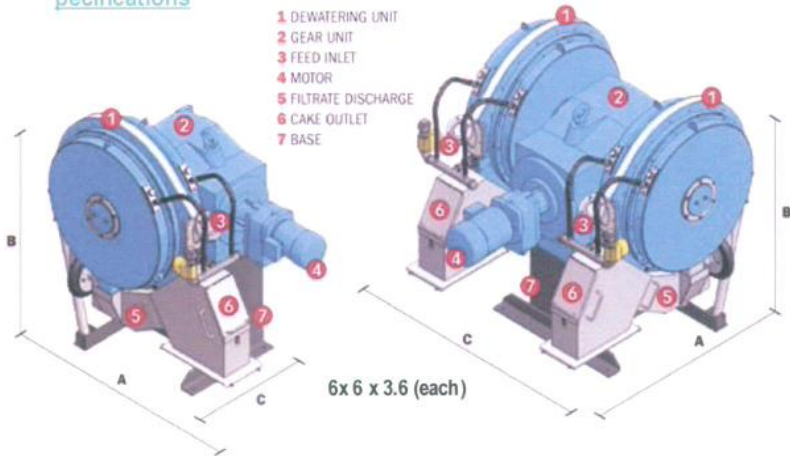

- 1 DEWATERING UNIT
- 2 GEAR UNIT
- 3 FEED INLET
- 4 MOTOR
- 5 FILTRATE DISCHARGE
- 6 CAKE OUTLET
- 7 BASE

6x 6 x 3.6 (each)



**OZONE GENERATOR 8000 MG/H**

<http://www.jenesco.com/>

**SLUDGE DRYER 600 S Model**

<http://www.watropur.com/en/standard-sludge-dryer/>



**SLUDGE DRYER HOPPER DIMENSIONS: 5.5 W, 4.3 L, 3.75' H**

**Sludge Dryer: 8.7 W, 4.2 L, 8' H**

1 Dairy Cow expels ~135 lbs of manure per day. 20 Flushes with a 5 Gallon Pressure Flush Toilet = (100 GPD = 835 LBS/Day) + Manure weight (135) PER COW = 970 lbs/day. 8 cows = 7760 lbs per day of sludge from cows alone

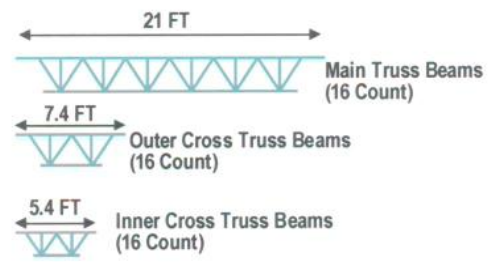
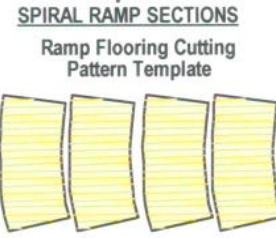
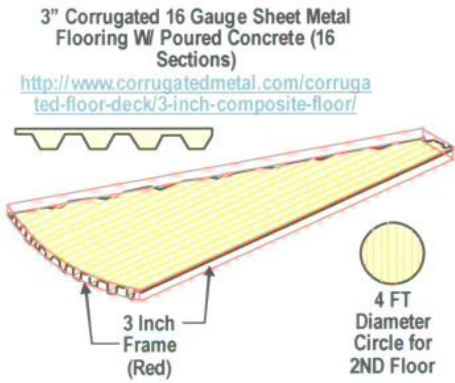
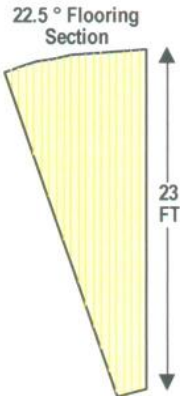
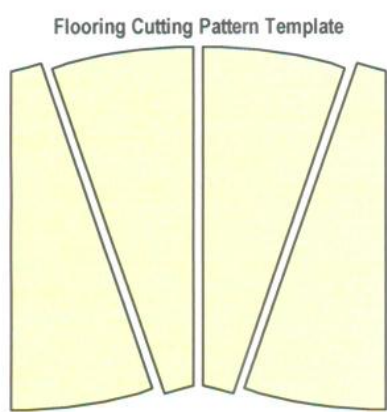
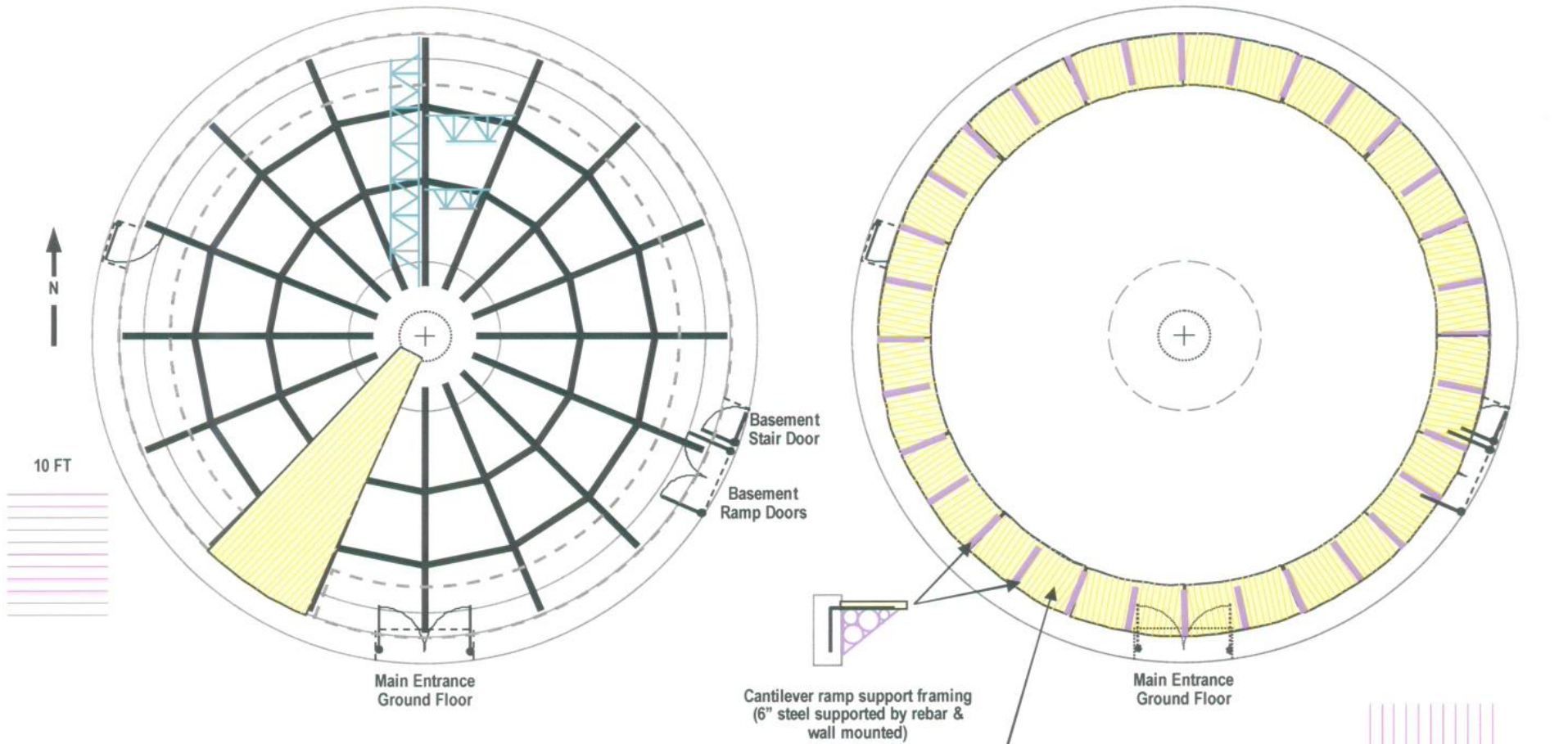

# HHO 500 Gal. Autoclave For Livestock Waste Treatment In 2 Hours (Class A Biosolids)

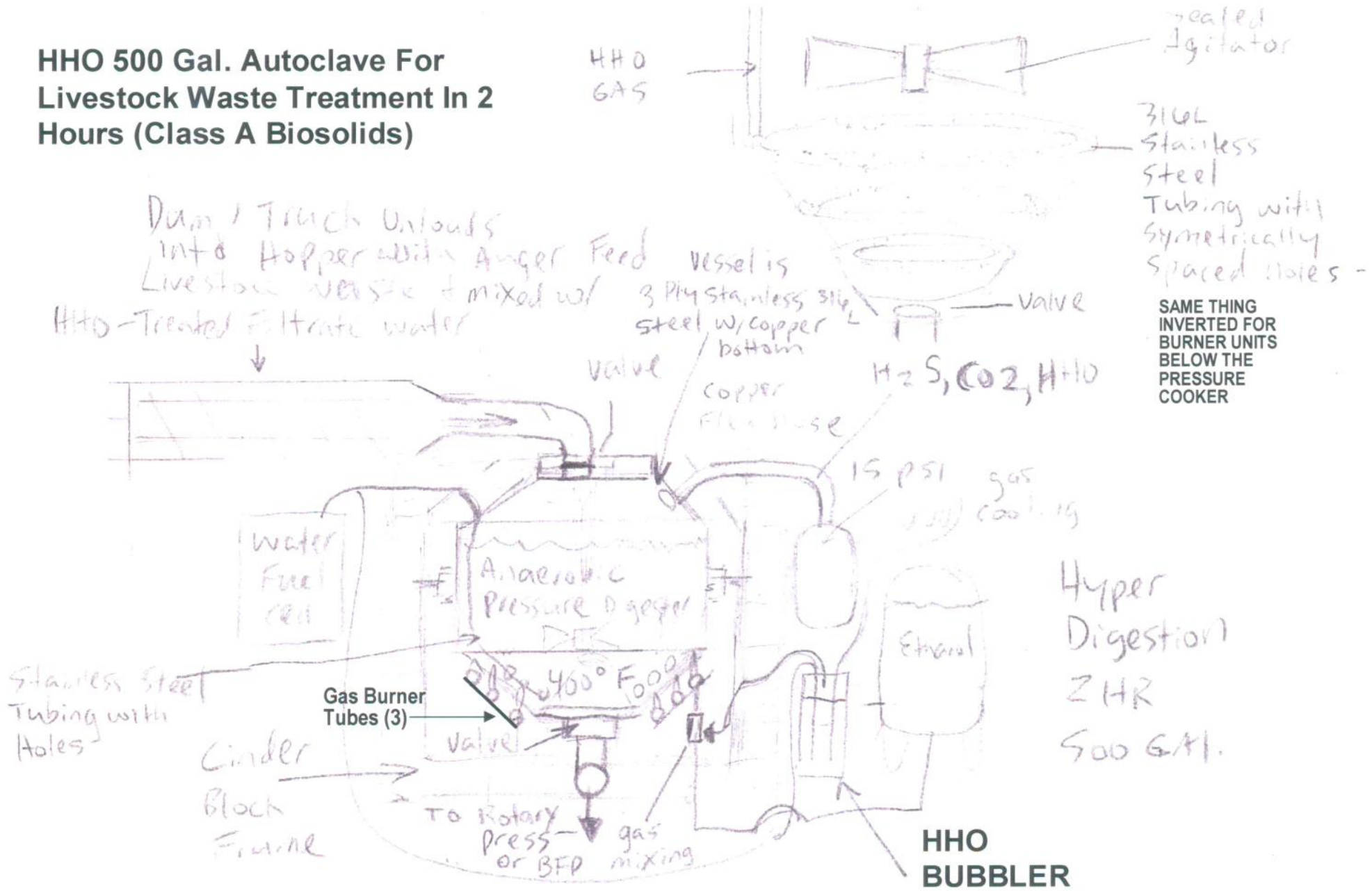

2 Hour Cook time @ 400°F MAX

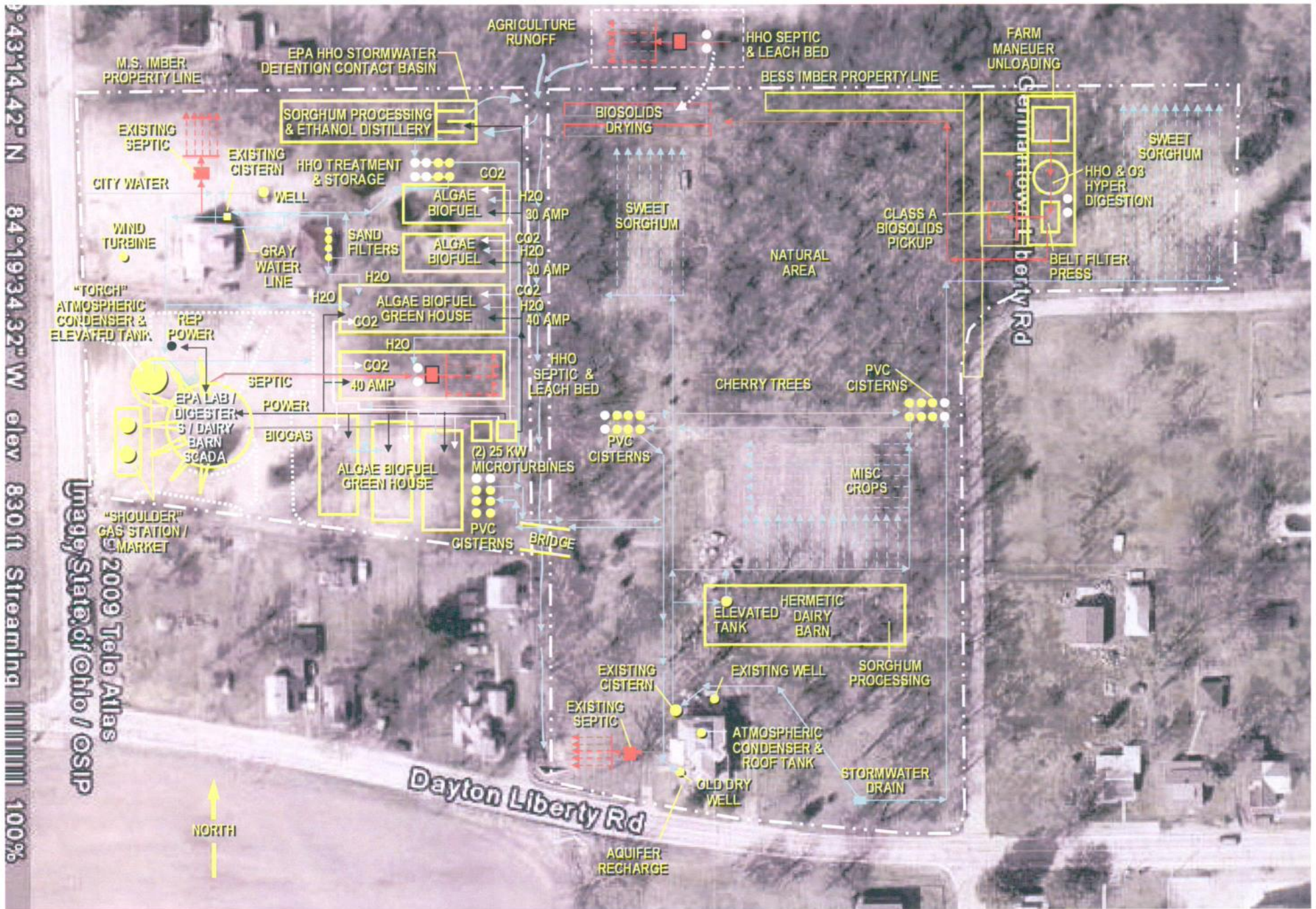

ADDRESS: 7915 Dayton Liberty RD, Dayton Ohio 45418

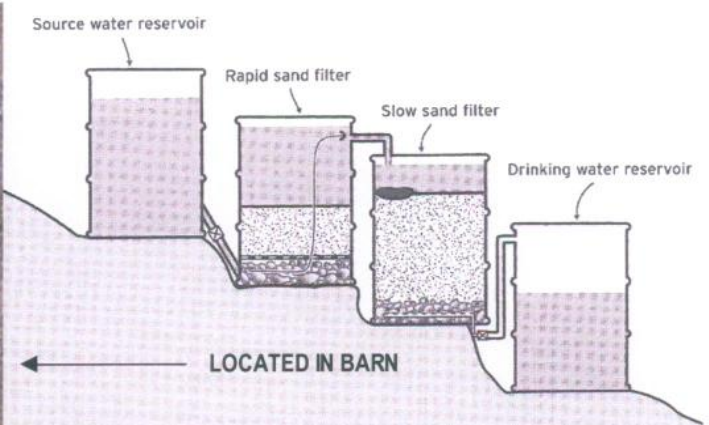
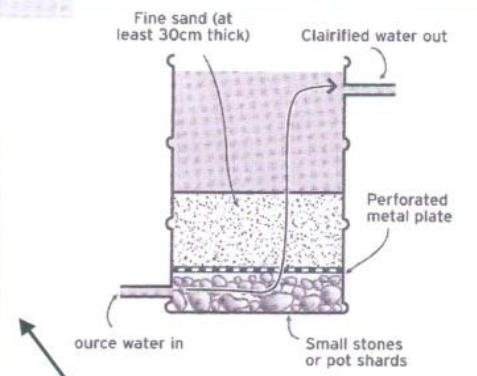
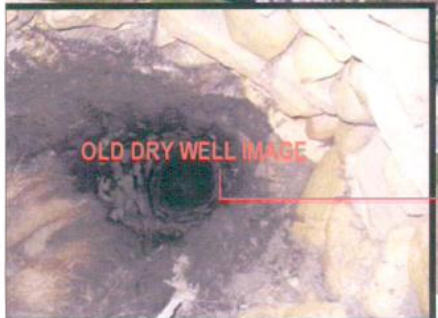

FIGURE 12c: GRAVITY-FED WATER FILTERING SYSTEM



OLD CHICKEN HOUSE FOR 1<sup>ST</sup> HHO CONTACT BASIN EXPERIMENT



OLD DRY WELL IMAGE

ADDRESS: 7915  
Dayton Liberty RD,  
Dayton Ohio 45418

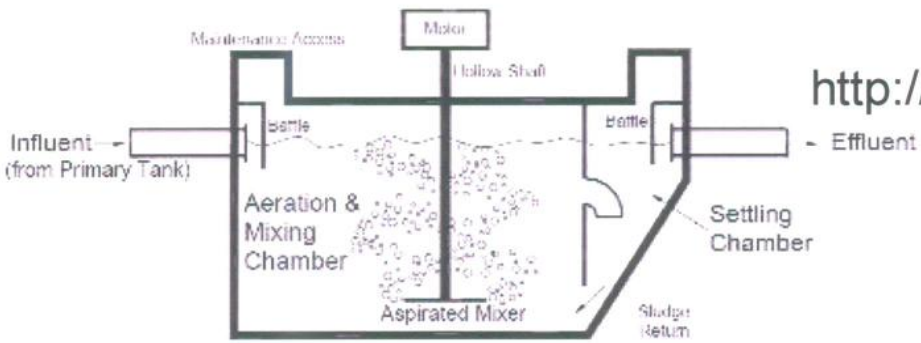

<http://www.inspect-ny.com/septic/septalts.htm>

[http://peswiki.com/index.php/Directory:Max\\_Whisson%27s\\_Gust\\_Water\\_Train\\_Apparatus](http://peswiki.com/index.php/Directory:Max_Whisson%27s_Gust_Water_Train_Apparatus)

Figure 5-3. Subsurface wastewater infiltration system design/performance boundaries.

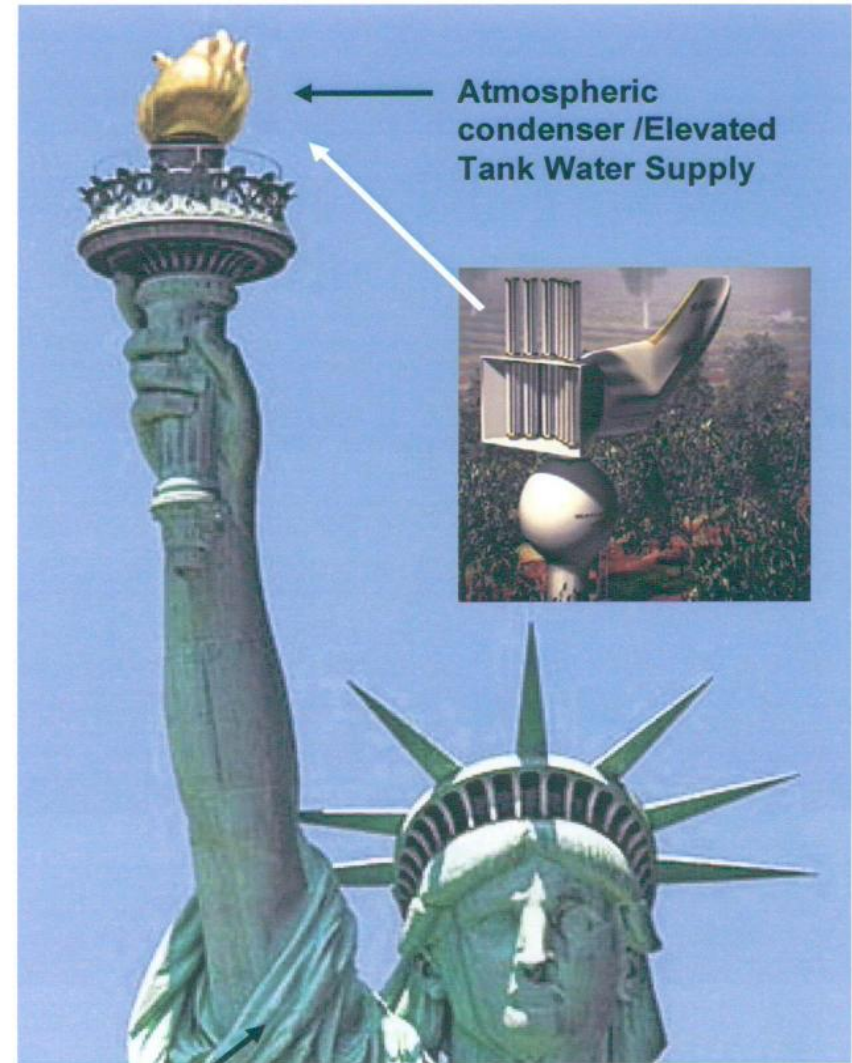
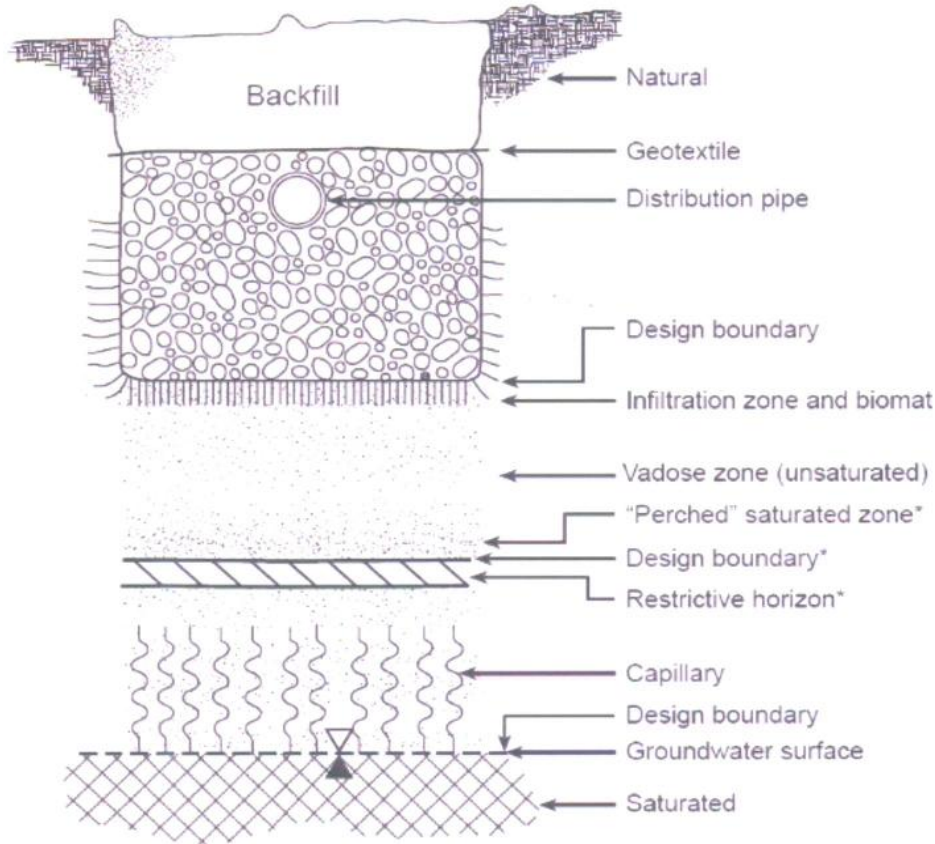

\* If present  
**Market Gas Station  
 & Tower Access**

# BioStar Thermophilic Anaerobic Digestion

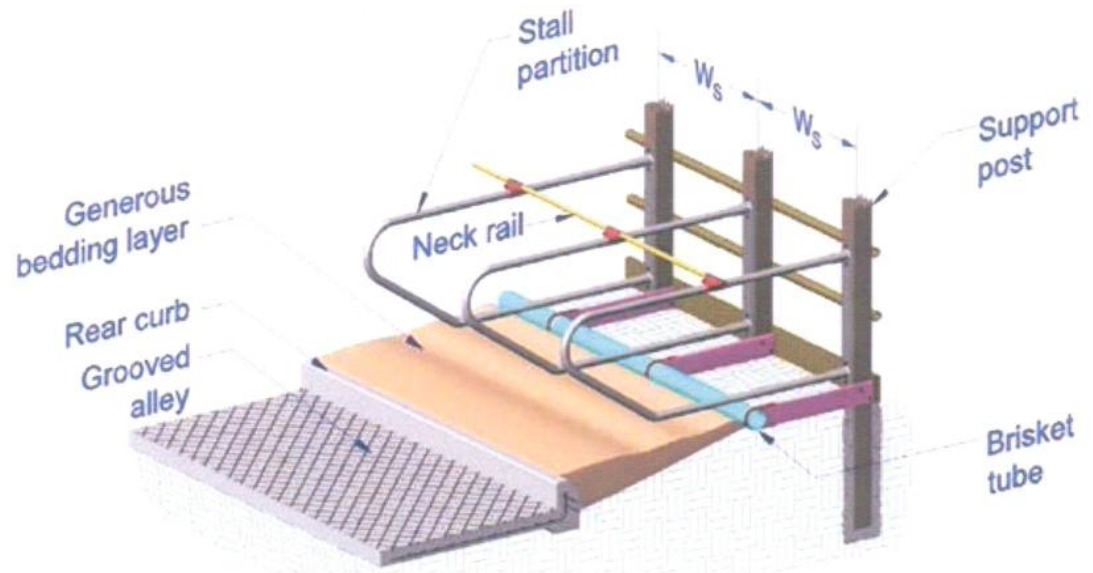
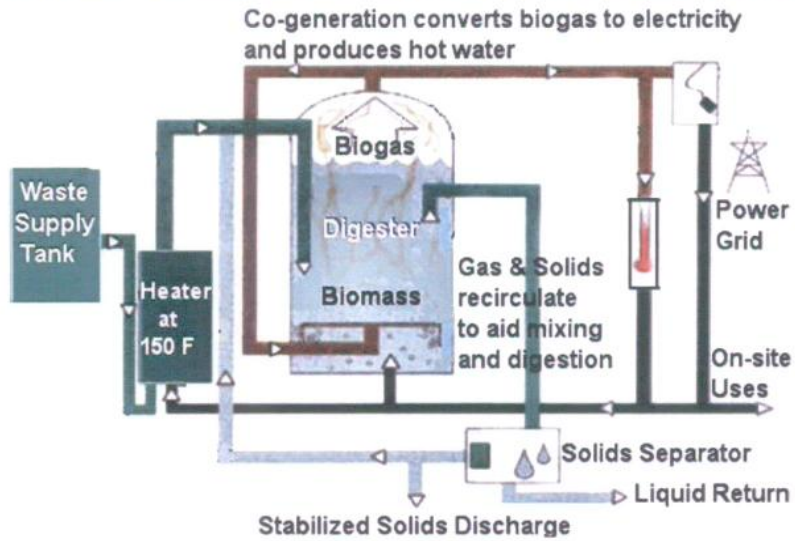

[http://www.extension.org/pages/Design\\_Considerations\\_for\\_Dairy\\_Cattle\\_Free\\_Stalls](http://www.extension.org/pages/Design_Considerations_for_Dairy_Cattle_Free_Stalls)

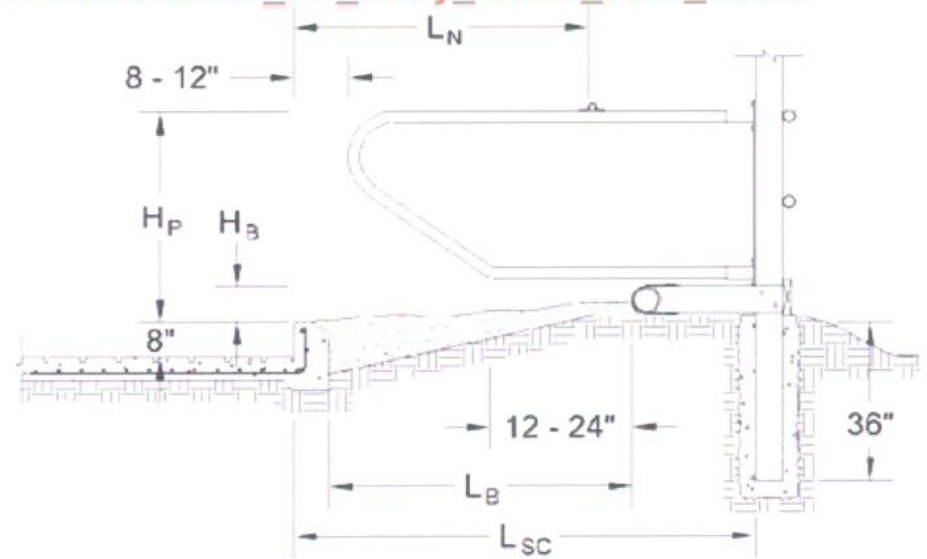
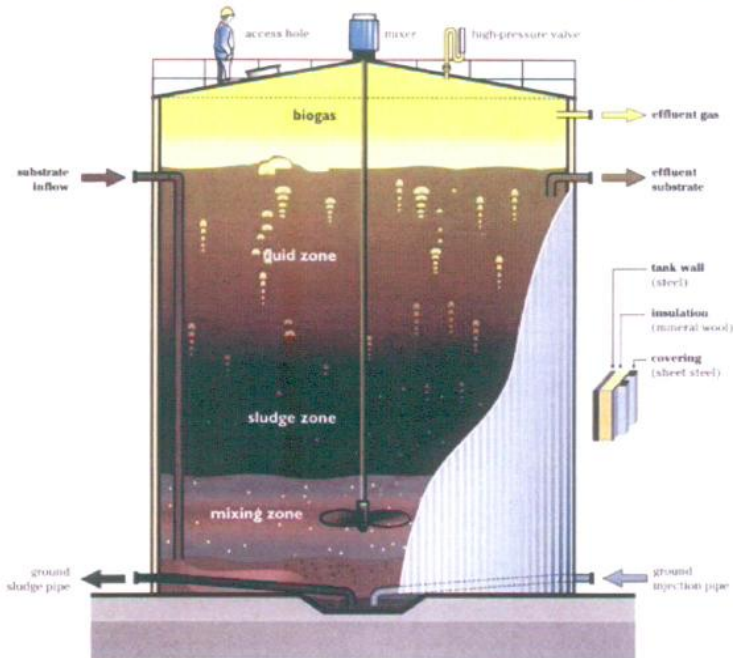

**Closed Front Freestall with Generous Bedding**



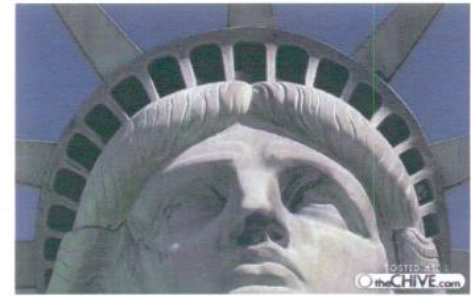
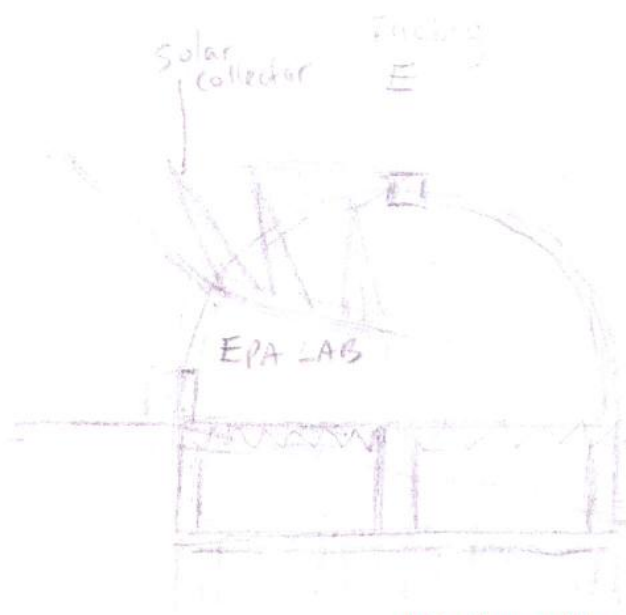

**ATMOSPHERIC CONDENSER SERVES AS LADY LIBERTY'S TORCH**

[http://peswiki.com/index.php/Directory:Max\\_Whisson%27s\\_Gust\\_Water\\_Trap\\_Apparatus](http://peswiki.com/index.php/Directory:Max_Whisson%27s_Gust_Water_Trap_Apparatus)

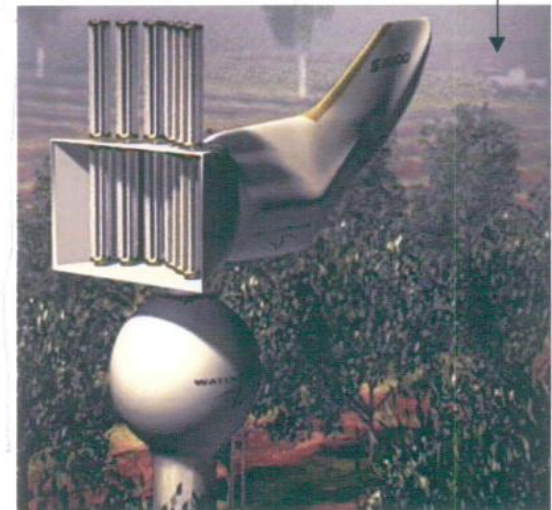
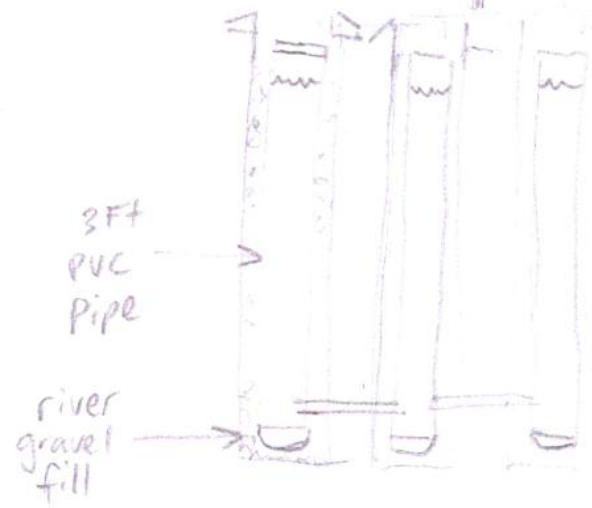
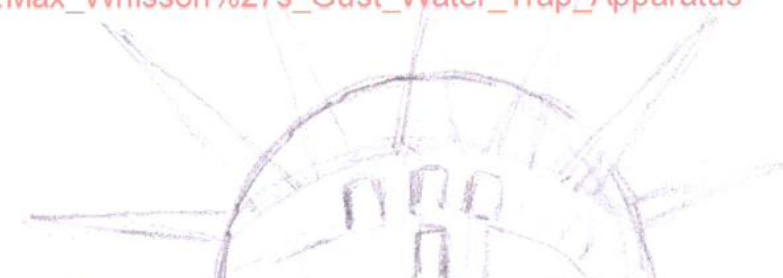



Primary Tesla Coil Winding

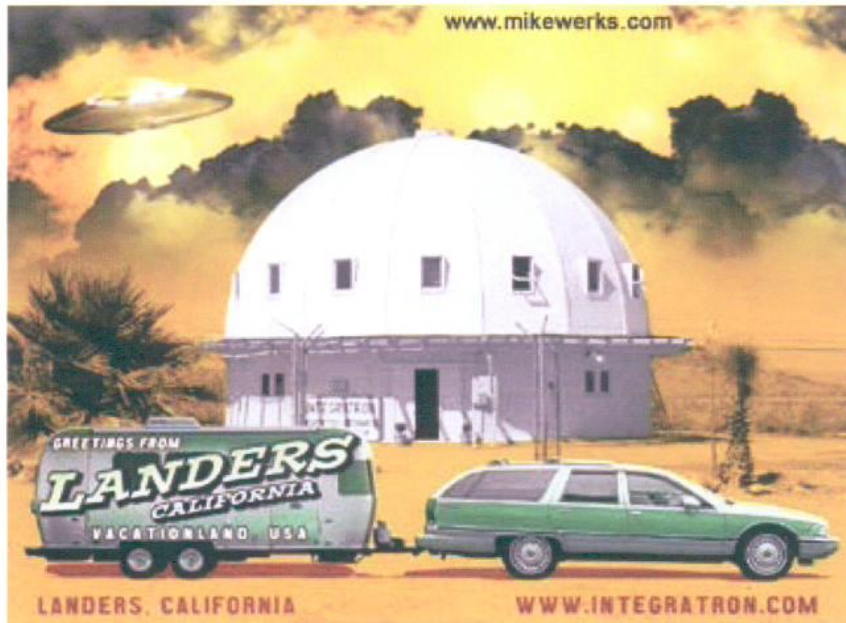

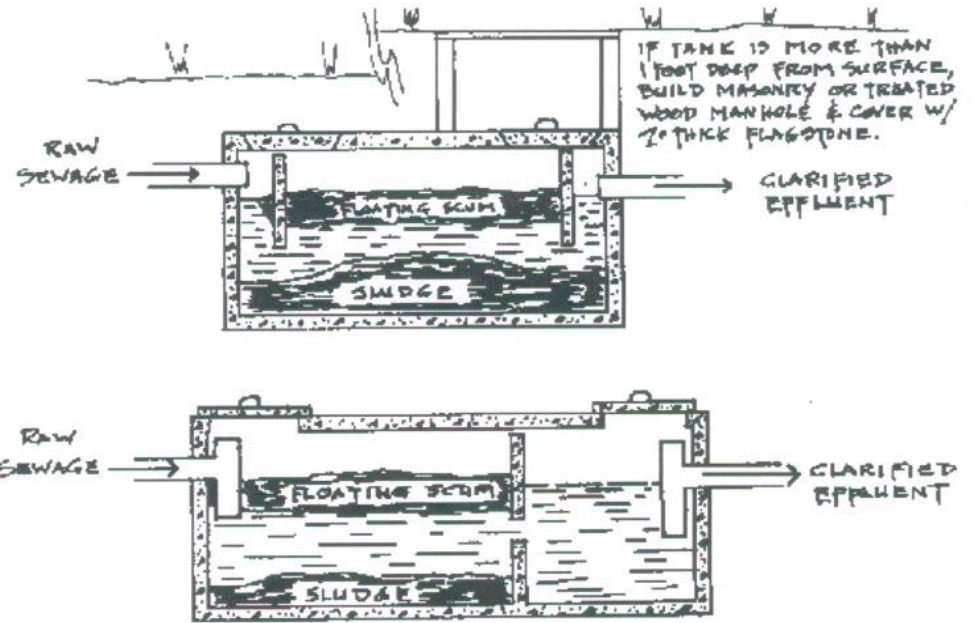
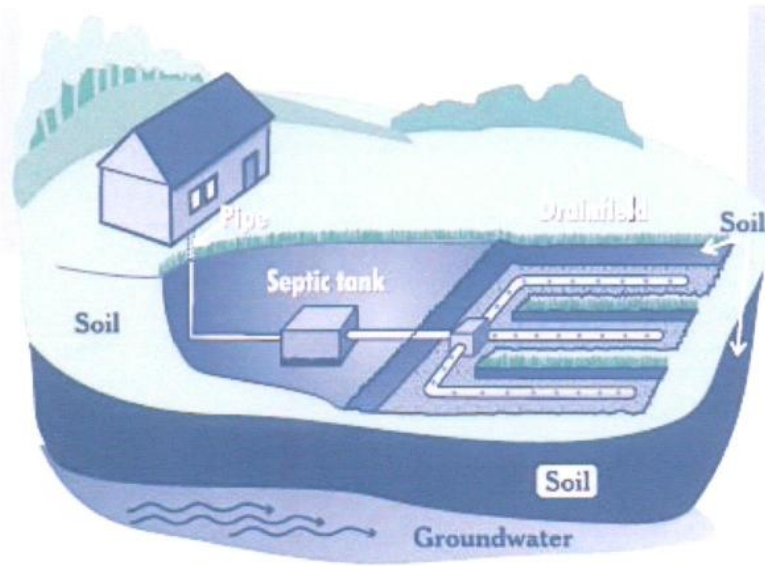

Two types of commonly used and approved precast-concrete septic tanks.

(C) 2006-1985 Daniel Friedman

